



**NEW**

**HIGH-EFFICIENCY REGULATED  
THREADED PUMPS NMT SMART 40**

**SMART**

**PERFORMANCE**

High efficiency ECM motor series pumps with canned motor and permanent magnets. Variable and constant pressure control through display. For use in water system according to requirements of VDI 2035.

**APPLICATIONS**

All heating systems, air condition systems, closed loop cooling systems and industrial circulatory systems.

**OPERATION**

- Auto mode (default)
- Proportional pressure control
- Constant pressure control
- Constant speed
- Night mode

**PRODUCT DESCRIPTION**

- High efficiency ECM technology
- Energy savings
- LED Display for control
- Easy handling and installation
- Plug & Play
- Robust and compact construction for long life
- Automatic venting
- Low noise operation
- Possibility of housing with cataphoretic
- Possibility of NMT communication module

Pump component	Material
Housing	Cast iron
Impeller	PES
Shaft	Stainless steel
Bearings	Graphite
Ventricular wall	Stainless steel
Rotor can	Stainless steel

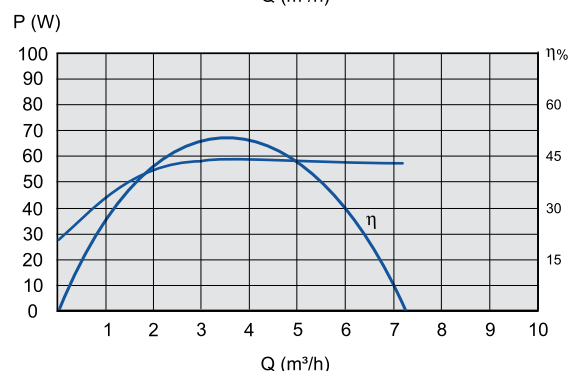
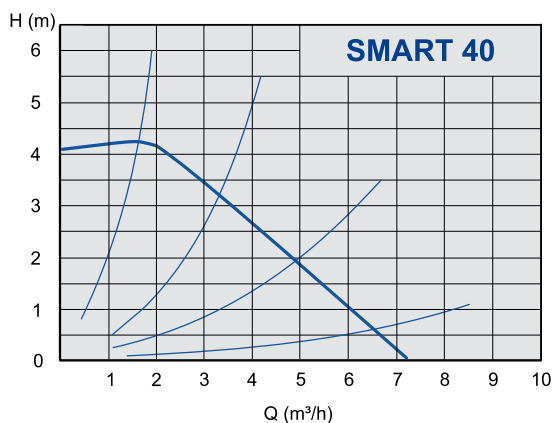

NMT	Pipe connection	DN	Fitting length	N. Pressure	Weight	Code	Euro
SMART 25-40	Rp 1	25	180 mm	PN 10 bar	4 kg	979523477	460,00 €
SMART 32-40	Rp 1 ¼	32	180 mm	PN 10 bar	4,1 kg	979523478	467,00 €
SMART C 25-40	Rp 1	25	180 mm	PN 10 bar	4,2 kg	979523488	603,00 €
SMART C 32-40	Rp 1 ¼	32	180 mm	PN 10 bar	4,3 kg	979523489	610,00 €

Dimensions	L	DN	D2	I
SMART 25-40	180	25	6/4"	190
SMART 32-40	180	32	2"	190
SMART C 25-40	180	25	6/4"	222
SMART C 32-40	180	32	2"	222

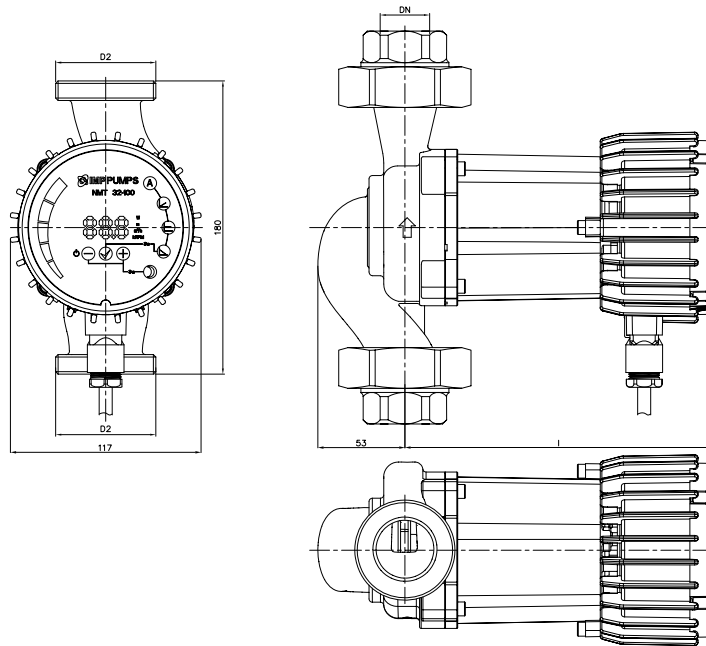

## TECHNICAL DATA

Flow Q up to 7,5 m<sup>3</sup>/h  
 Pressure H up to 4 m  
 Power 7 - 60 Watt  
 Nominal pressure 10 bar

### Permissible mediums

- Water, mixed with glycol, parameters must be checked in the mixture of water with over 20% of glycol
- Pure non-explosive liquid media free from mineral oils and without solid particles

### Permissible temperature range

- Medium temperature from +2 °C to +110 °C with max. surroundings temperature up to +40 °C

### Minimum inlet pressure

0,05 bar < 75 °C Temperature of medium  
 0,28 bar < 90 °C Temperature of medium

### Electrical connection

Voltage 1 ~ 230 V, 50/60 Hz

### Motor/Electronics

- Motor with permanent magnets
- The energy index EEI ≤ 0,21
- Built-in motor protection
- 3 control modes (proportional head, constant head, constant speed)
- Degree of protection: IP 44
- Insulation class F