

Series
VENTS VKMK



Centrifugal roof fans with the air capacity up to **1880 m³/h** in the steel casing with the horizontal exhaust of air

■ **Applications**

Exhaust ventilation system for various premises. Suitable for mounting on any roof types as well as connection to Ø 150 up to 315 mm round air ducts.

■ **Design**

The fan casing is made of steel with polymeric coating. A thin steel connection plate is provided at the bottom of VKMKp model.

■ **Motor**

The centrifugal impeller with backward curved blades is powered by means of the single-phase motor with external rotor. The motors are equipped with thermal overheating protection with automatic restart as well as ball bearings for long service life. For precise features, safe operation and low noise of the fan, each turbine is dynamically balanced while assembly. Motor protection rating IP 44.

■ **Speed control**

Smooth or step speed control is performed by means of the thyristor or autotransformer controller. Several fans can be connected to one controller in case the total power and operating current do not exceed the rated controller values.

■ **Mounting**

The fan is mounted on the roof directly above the ventilating duct or shaft and is firmly fixed to the flat surface by means of a connecting plate. Electrical connection and mounting shall be performed in compliance with the manual and wiring diagram on the terminal box.

Technical data:

	VKMK 150	VKMK 200	VKMK 250	VKMK 315
Voltage [V / 50 Hz]	230	230	230	230
Power [W]	98	154	194	296
Current [A]	0,43	0,67	0,85	1,34
Maximum air flow [m ³ /h]	555	950	1310	1880
RPM [min ⁻¹]	2705	2375	2790	2720
Noise level at 3 m [dBA]	47	48	52	54
Maximum operating temperature [°C]	-25 +55	-25 +50	-25 +50	-25 +45
Protection rating	IP X4	IP X4	IP X4	IP X4

Fan overall dimensions:

Type	Dimensions [mm]					Mass [kg]
	ØD	ØD1	H	L	L1	
VKMK 150	149	400	230	440	330	7,2
VKMK 200	198	400	250	440	330	8,1
VKMK 250	248	400	249	590	450	10,1
VKMK 315	315	500	269	590	450	10,1
VKMKp 150	149	400	230	440	330	8,2
VKMKp 200	198	400	250	440	330	9,3
VKMKp 250	248	400	249	590	450	12,3
VKMKp 315	315	500	269	590	450	12,2

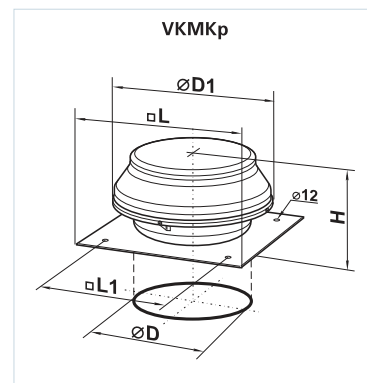
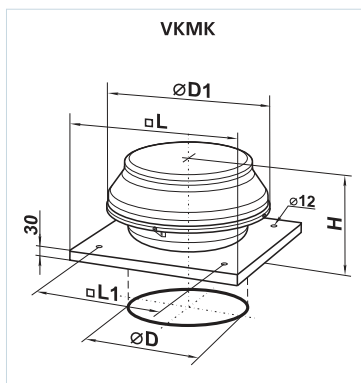

Designation key:

Series	Flange diameter, mm
VENTS VKMK	150; 200; 250; 315
p – with a flat connection plate	

Accessories



page 0 page 0 page 0 page 0 page 0 page 0 page 0 page 0 page 0 page 0

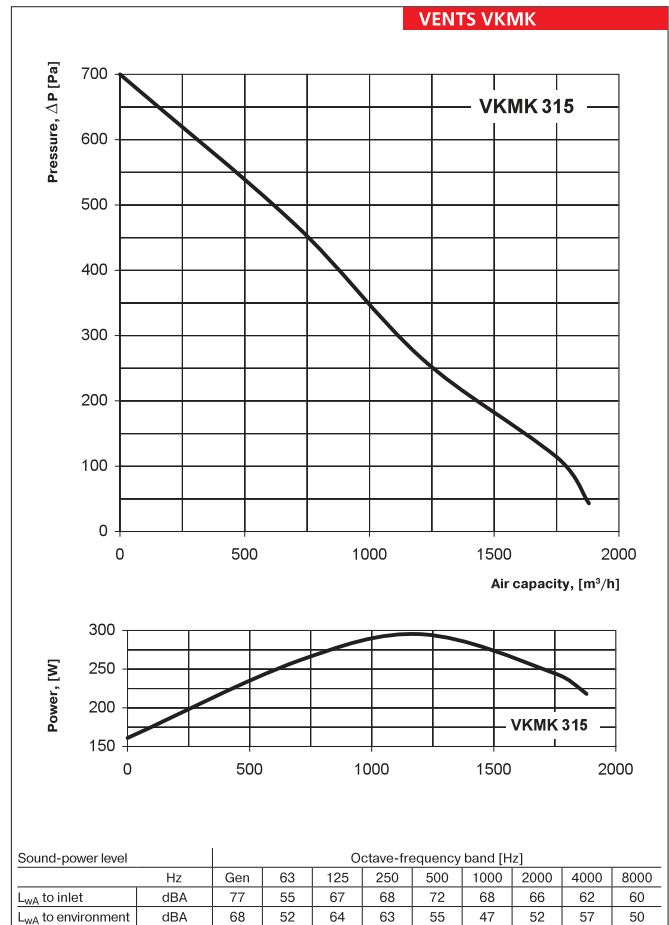
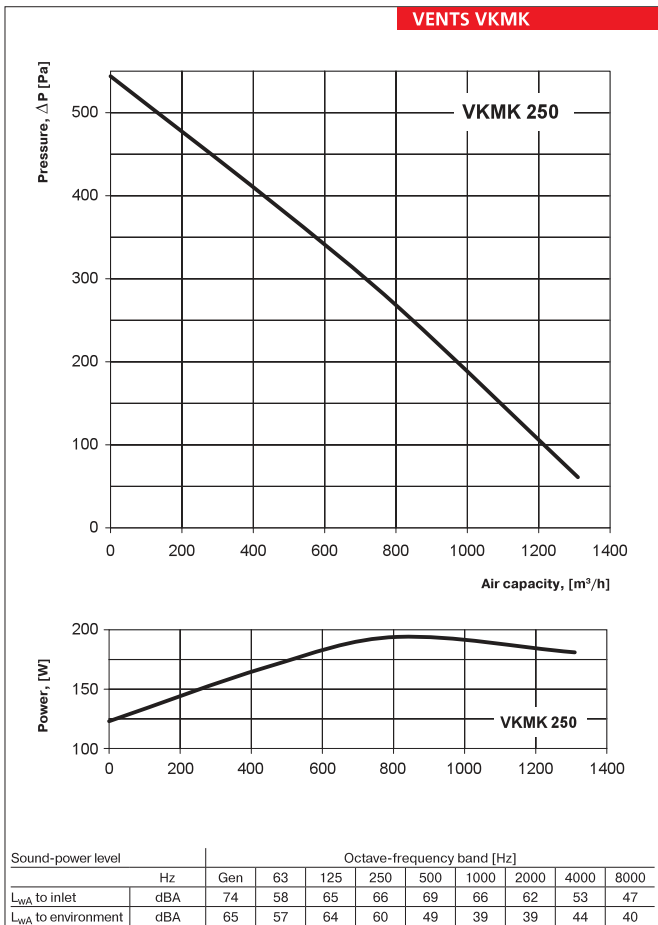
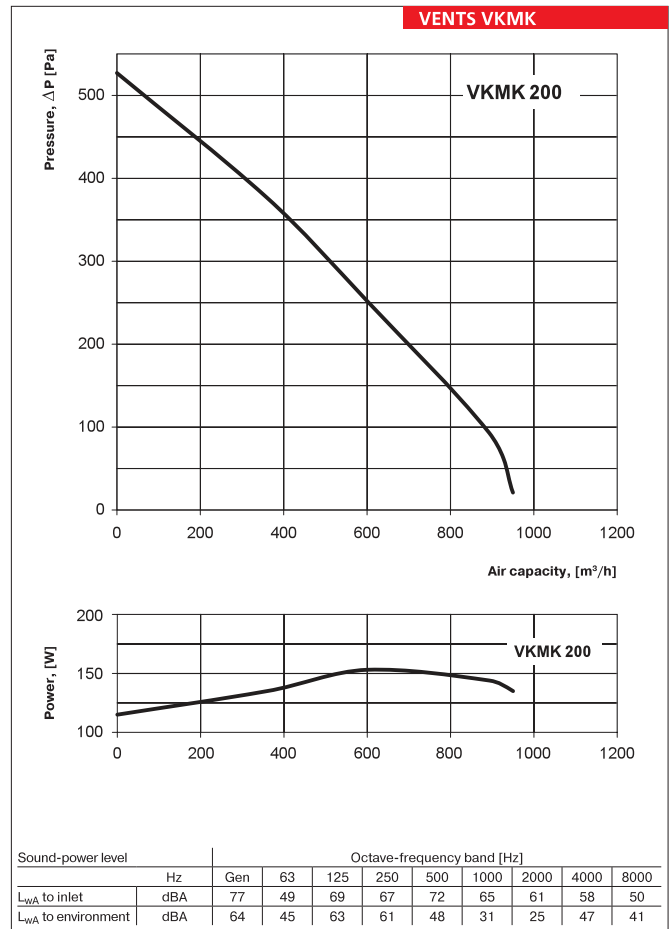
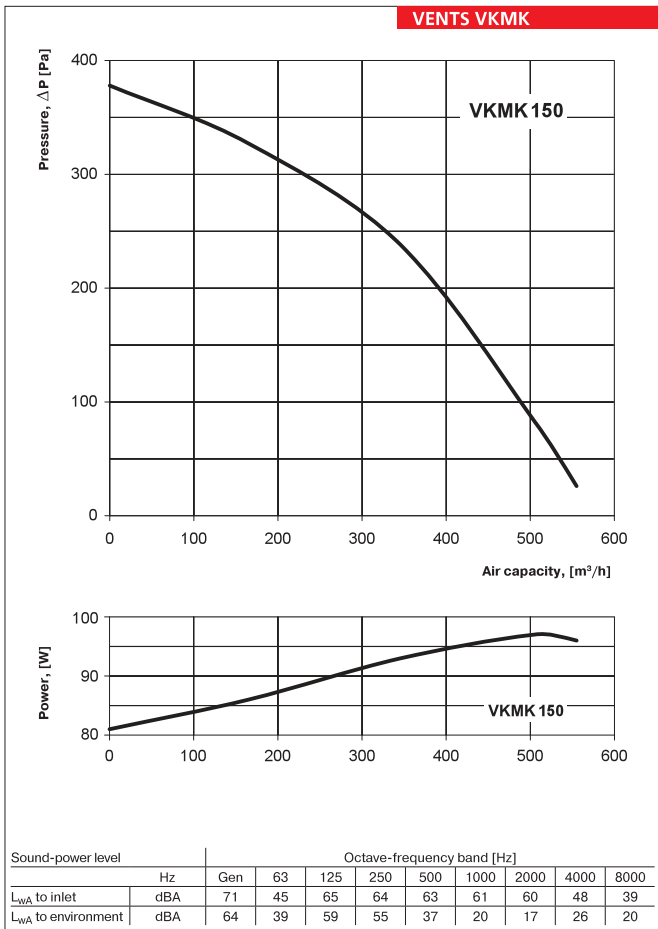

VENTS VKMK
FAN SERIES